

EDUCATIONAL PERSPECTIVE ON THE DESIGN AND IMPLEMENTATION OF A 2KVA MODIFIED SINE WAVE POWER INVERTER

Icheke, L. E.D

Abstract

This paper presents the design and implementation of a 2kVA modified sine wave power inverter. The inverter converts the direct current (DC) to an alternating current (AC) with approximately 120 electrical degree phase angle. The system produces a single phase modified sine wave output voltage from the direct current (DC) battery supply. Power semiconductors and power transformer are utilized for the conversion of the direct current (DC) to an alternating current (AC) for a single phase model. The output voltage magnitude and the switching frequency of the power transistor are controlled using digital integrated circuit (IC). The system has a change over unit for the utility power and inverter power supply. The rated power output of the system is 2kVA, the output voltage is 220V (AC) and the frequency is 50Hz. The inverter functions effectively between 12.5V (DC) to 10.5V (DC) battery supply voltage. The inverter can be used as standalone energy source for domestic applications and to power single phase motor drivers. A fully charged 75 A-H (Ampere-Hour) battery can be utilized by the inverter to power a 2000 watts load for a period of six (6) hours

Keyword: Modified Sine Wave Inverter

Introduction

Power inverter is an electrical electronic device that converts direct current (DC) power to an alternating current (AC) power. The transformer utilized is a step-up transformer. The 12V (DC) from the battery is applied to the center tap of the transformer, the two other primary terminals are connected to the drain of the power transistor Q_1 and Q_2 . The transistor is switched ON and OFF alternatively with the signal from the integrated circuit TL494. The TL494 is a pulse width modulated integrated circuit (IC). As a result of the changing voltage at the input terminal of the transformer an alternating current is developed. The transformer step-up the voltage and a high voltage is obtained at the output terminal of the transformer. The output voltage obtained depends on the frequency by which the transistor is switched ON and OFF. If the frequency is very high it can result to an output voltage of 400V and above. The frequency of the inverter is controlled with the parameters in equation 1. The output of the inverter is uninterruptable because the change over unit is used to switch ON the power supply from the utility power supply to the output socket or the battery to power the inverter when the utility power supply fails. The filter network at the output is used to modify the output wave form to a sine wave such that it can be used to power an inductive load without humming. The fraction of the output voltage is feed back to the input rectifier through the step-down transformer. This enables the stability of the system and in order not to drain the power of the battery easily. The inverter can maintain the supply to load efficiently with the battery supply ranging from 12.5V (DC) to 10.5V (DC). This unique feature makes the battery supply to last for a very long time. The inverter is a modified sine wave which can be used to power resistive loads, inductive loads and motor drives. Revolutionary advances in semiconductor technology have made it possible and have significantly improved

power handling capacity and the switching speed of power semiconductor devices used in power inverters.

In order to minimize power loss when controlling the flow of electrical energy, it's crucial to select the appropriate power semiconductor devices to give the appropriate switching frequency and the required power. Electronically triggered switches (power transistor) such as Metal-Oxide semiconductor field effect transistors (MOSFETs) are used. There have been several paper presentations on power inverters. Rahamam, Braddy, Brayan, (2007), presented a sinusoidal triangular pulse width modulated (SPWM) technique to implement a microcontroller based three-phase voltage power inverter. The simulation result shows that the width of the pulse has a sinusoidal variation throughout the period of the control signal, hence a modified sine wave inverter. Marei M., El-Saadanu, & Salama, (2002), presented a voltage inverter technology for power conditioning system (PCS) for utility interface of solar energy, based on power generated by Photovoltaic (PV) method. The power is processed through two stage configuration using inductors and capacitors to form what is described as shoot through state and the inverter state. Dragan, Aleksandar, Joseph, George, 2001), presented a hybrid three-phase power inverter. The outputs are connected in parallel to form a common DC link to the power transformer for the DC to AC conversion. It should be noted that power inverter does not have higher power output when compared to utility power supply and nuclear power systems. In this presentation, a critical analysis of battery power for the purpose of electricity generation using the power inverter for a single phase model is considered. The inverter produces a modified sine wave output. A fully charged 75 A-H (Ampere-Hour) battery can be utilized by the inverter to power a 2000 watts load for a period of six (6) hours

Objectives

The main objective of this work is to determine the conversion of direct current (DC) power from the battery to an alternating current (AC) power with modified sine wave output, feeding the load efficiently. The specific objectives are as follows;

- To determine the maximum power rating of the inverter.
- To determine the minimum/maximum input voltage range from the battery to produce an effective output voltage to power the load.
- To determine the output frequency of the inverter.
- To determine the output voltage/current of the inverter under infinite load and under load conditions.
- To determine the infinite load current of the inverter

Block diagram of the inverter

The block diagram of the power inverter for the conversion of the DC power from the battery to an AC power is shown in figure 1. It includes the battery, the detection circuit, the changeover, the bridge rectifier, the power transistor (MOSFETs), the power transformer, the filter network, the buffer and the pulse width generator TL494N.

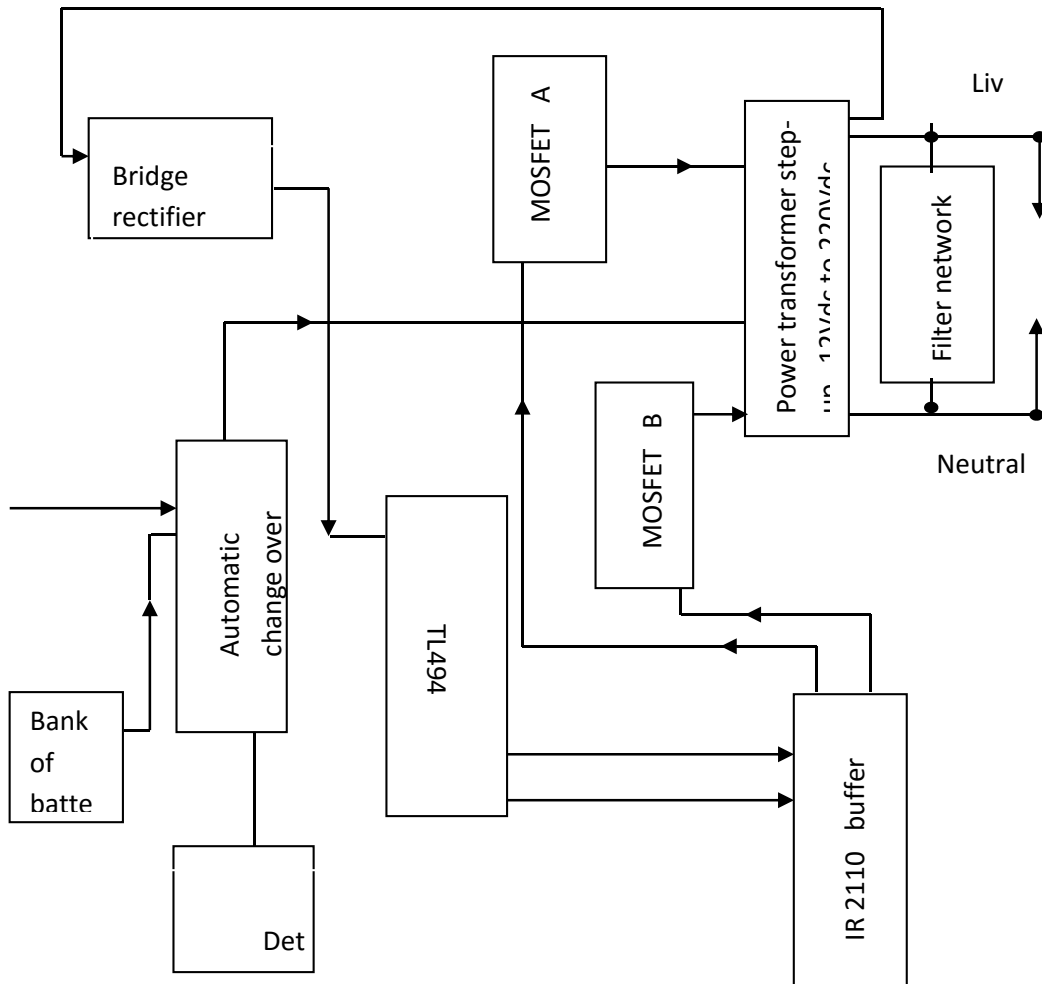

Figure 1:

The block diagram of 2kva modified sine wave power inverter

The operation of the system can be interpreted from the circuit diagram of figure 2a and 2b below. The battery provides the needed DC power to power the inverter. The bridge rectifier is connected to the transformer low winding output; it provides the feedback voltage to the TL494N digital integrated circuit that generates the PWM signal. The utility power supply is connected through the changeover system that will either connect the utility power to the output or the battery output to the center tap of the step-up induction transformer. The detection circuit is used to set the switching points of the changeover system to either switch the output of the utility power to the required point or the battery to the center tap of the transformer. The TL494N generates the PWM signal that switches the MOSFETs (IRFP I50N) ON and OFF alternatively through the buffer IR2J10 interface.

The MOSFETs are connected in cascade of three in each case for a 2kva design via the transformer terminal for the step-up of the alternating current from the primary terminal to the secondary terminal. The resistor capacitor filter network at the output removes the ripple and the DC components and modifies the output wave form. The output is a modified sine wave with

minimal harmonic contents. The TL494N is a fixed frequency pulse width modulator control circuit. An internal linear saw tooth oscillator is frequency programmable by two external components resistor ($R=100k$ ohms) and capacitor ($C_T=104k$ ceramic capacitor). The approximate oscillating frequency is determined by

$$f_{osc} = 1.1 / R_T \times C_T$$

The output pulse width modulation is accomplished by comparison of the positive saw tooth waveform across the capacitor C_T to either of the two control signals. The NOR gates which drives the output transistor Q_1 and Q_2 are enabled only when the flip-flop clock input line is in its low state. This happens only during the portion of the time when the saw tooth voltage is greater than the control signal amplitude causing a corresponding linear decrease of the output pulse width. The control signal are external input that are fed into the dead time control, the error amplifier inputs or the feedback input from the transformer are connected through the bridge rectifier to pin 1 of the TL494N.

The pulse width modulator comparator provides a means for the error amplifier to adjust the output pulse width from the maximum percent on time, established by the dead time control input down to zero, as the voltage at the feedback pin 1 varies from 0.5v to 3.5v. When capacitor C_T is discharged, a positive pulse is generated on the output of the dead time comparator which inhibits the output transistor Q_1 and Q_2 . With the output control connected to the reference line, the pulse steering flip-flop direct the modulated pulses to each of the two output transistors alternatively for a push-pull operation. The output frequency is equal to half that of the oscillator. The output drive is taken from Q_1 and Q_2 in single ended operation with the maximum on time less than 50%. Figure 2a and 2b are connected together through the point A and B in the system circuit diagram.

The system circuit diagrams

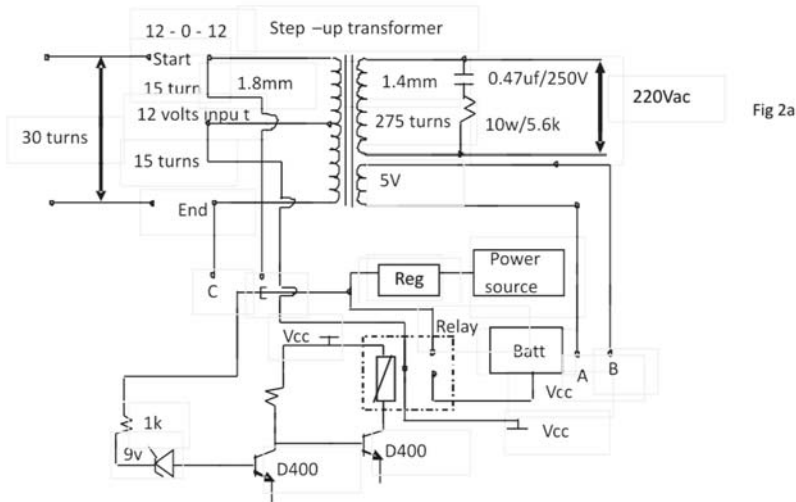

Fig 2a

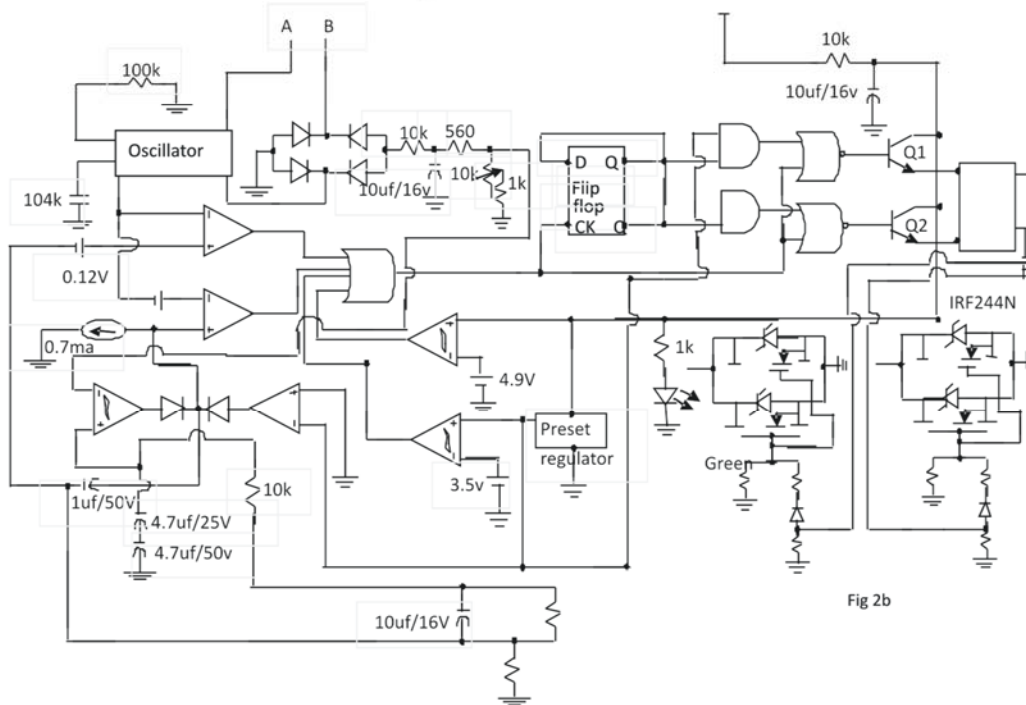

Fig 2b

The pulse width signal

The TL494N is used to generate two levels on its output lines, High and Low. The signal remains "ON" for some time and "OFF" for some time, T_{ON} = Time the output remains high, T_{OFF} = Time the output remains low, T = Time period = $T_{ON} + T_{OFF}$. The FWM period is an arbitrarily time period in which PWM takes place, it is chosen to give best result for a particular

design. =

$$\frac{T_{ON} \times 100\%}{\text{Time Period}}$$

The duty cycle is the percentage total time the output was high over the total period. The PWM technique utilizes this fact to generate signals between two extremes. The trick is to vary the duty cycle between 0-100 percent and get the percentage of input voltage to output. As the pulse approaches 100% "ON" time, the duty cycle approaches 100%. Similarly as pulse approaches 0% "ON" time, the duty cycle approaches 0%.

The switching dead time

In the real switch hypothesis, the occurrence of switch cross conduction can be easily prevented by imposing, under any circumstance, logically complementary gate signals to the two switches. Unfortunately in real-life case, this is not sufficient condition to avoid cross conduction. In real switch commutations, it requires a finite amount of time and the commutation is a complex function of several variables such as commutation current and voltage, gate drive current, temperature, etc; therefore, it is impossible to rely on complementary logical signals as an effective protection against switch cross conduction. The introduction of communication dead-time, i.e. suitable delay before the switch turn ON signal is applied to the gate is necessary. The wave form of the switch dead time control, the PWM signal, the clock signal, the outputs of the transistor Q₁ and Q₂ of the control integrated circuit TL494N are well configured to avoid cross conduction.

Filter network

In the output stage, the resistor capacitor (RC) filter network figure 4 is used to filter out the harmonic and ripple contents and modifies the output wave form to a sine wave so that the supply can power inductive loads like compressors, Fans and electrical machines efficiently.

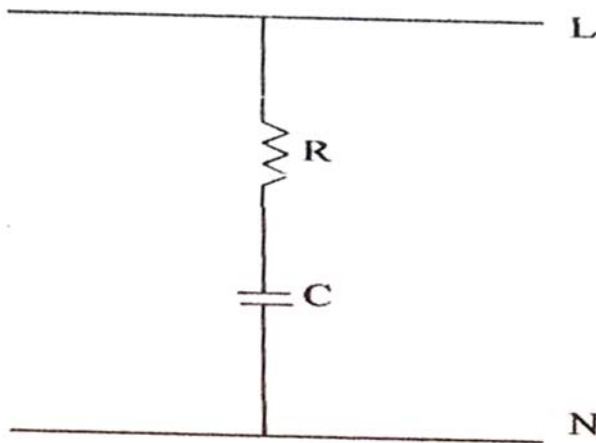

Figure 3: the filter network

The wire size

The primary and secondary wire size of the transformer to withstand the current are chosen from the standard wire gauge chart, 4mm copper wire is selected for the primary while 2mm is selected for the secondary, the feedback wire size is 0.8mm. These sizes of wires were used to wound the transformer to obtain the required results.

Results

The table 1 below shows the result obtained from the test conducted in the Laboratory

Table 1

I/P Vdc	Load (W)	Freq (HZ)	O/P(Vac)	O/P(Isc) A
12.5	600	53.64	220.8	11.05
	1000	53.2	220.7	11.03
	1600	53.05	220.6	11.02
	2000	53.00	220.5	11.00
11.5	600	52.43	220.4	10.97
	1000	52.34	220.1	10.93
	1600	52.26	210.8	10.86
	2000	52.08	210.6	10.67
10.5	600	51.72	210.3	10.61
	1000	51.04	200.5	10.54
	1600	51.56	200.3	10.38
	2000	51.49	190.7	10.20

Discussion of the results

The 2kva power inverter has been designed and the prototype constructed. The prototype is wired on a Vero board. The testing was carried out in the laboratory set up with battery power and the results obtained were recorded in table 1. The inverter was used to effectively power 2000 watts load as shown in table 1, the maximum rated power is 2kva since the system can withstand 2000 watts load, it means that the rated power is 2kva, this shows that the first main objective of the work has been actualized, when there is an increase above this capacity the system voltage and current falls to a lower value. From the table 1 the inverter was tested with variable load in watts when the input voltage of the battery was between 12.5V (DC) and 10.5V (DC) and the inverter were able to withstand the loads, with the output frequency of 52.38 Hz approximately, this shows that the second and the third objectives have been realized. The output voltage and current under infinite load condition was 230V (AC) and 11.20A (ampere) respectively. Under load condition various output voltage and current were recorded in the table 1. The infinite load current is 0.85 ampere which means that the current drawn by the inverter at infinite load condition is very small and negligible. This shows that the fourth and fifth objectives have been realized.

The system incorporates a sensing circuit such that at infinite load, there is no power at the output and the current drawn by the inverter from the battery is negligible, hence the last objective is actualized. From table 1 the frequency, the output voltage, and current are fairly constant, this further proves the stability of the inverter as it does not drain the battery voltage easily. When battery voltage is 10.5V, the output voltage is 190.7V (AC) showing a decrease as a result of combined effect of applied load and the reduced battery voltage.

Conclusion

The utilization of battery supply as a source for a single phase direct current (DC) to alternating current (AC) power inverter has been presented. The conversion is controlled by the pulse width modulated signal from the TL494N integrated circuit through the buffer. A prototype laboratory model of the power inverter was constructed and tested in the laboratory. The output voltage, output current, and the frequency were measured as recorded in table 1. The result shows that the system is a modified sine wave inverter and can be used as a stand-alone power supply system for domestic applications and motor drives. A Fully charged 75 A-H (Ampere-Hour) battery can be utilized by the inverter to power a 2000 watts load for a period of six (6) hours.

References

- Abdulatif A., (2009). A Matlab/Simulink based tool for power electronic circuits, *World Academy of Science Engineering and Technology*, (49) 274-279
- Ben Y., (1994). Average simulation of PWM converter by direct implementation of behavioral relationship, *INT .J, Electronics*, 77 (5) 731-746
- Dragan M., Aleksandar M., Joseph V., George C., (2001), Modeling and simulation of power electronic converters, *Proceeding of IEEE*, 89 (6) 898-910
- Erickson R., Maksimovic W., (1997), Fundamentals of power electronics, Second Edition, *New York: Chapman and Hull*
- Gedigas S., Marguardi R., Sommer R., (1995), High power IGBT converter with new gate drive and protection circuit, *EPE 95*, 1066-1070
- Gole A., Albert K., Gunther E., Dommel H., Hassan I., Marti J., (1997). Guideline for modeling power electronics in electric power engineering applications, *IEEE Transaction on Power Delivery*, (1) 505-514
- Ham N., Hermerton C., and Sharples D., (1994), *Power semiconductor application laboratory of Philips semiconductor products division Hazal grove.*
- Kazmierkowski M., Krishnan K., and Blaabjerg F., (2002). Control in power electronics, *Elsevier science and technology book*, 4-27
- Marei M., El-Saadanu E., and Salama M., (2002). Flexible distributed generation, *Proceeding of IEEE Power Engineering Society*, (1) 49-53
- Mekene S., Hiley J., Keith B., (1988). Electrical technology, eight Edition by Hughes, *Singapore: Pearson Education*, (710-717)
- Mitsubishi Electric Power Semiconductor (2015) on Line Available, [http: www.mitsubushichip.com](http://www.mitsubushichip.com)
- Paul H., Winfield H., (1995). *The art of electronics publish by press syndicate of University of Cambridge*, Pp 44-56
- Rahamam M., Braddy B., Brayson S., (2007). A microcontroller controlled power factor corrected AC-DC boost converter with discontinuous conduction mode (DCM) operation, *proceeding of American Society for Engineering Education Illinois*, Pp 22-26